



Optronics Systems Specification Mission and High-level Behavior co-validation

Jean-Charles Causse
Pascal Lebaillif
Jean-Marc Perey
Jean-François Le Roux
Xavier Warzee

Information included in this document are Thomson-CSF group's own property. These ones shall not be disclosed without the prior written consent of Thomson-CSF Optronique.



DT / Génie Optronique

Information included in this document are Thomson-CSF group's own property. These ones shall not be disclosed without the prior written consent of Thomson-CSF Optronique.

REF_T00_EN - Outil PowerPoint



Scope and Goals

Les informations contenues dans ce document sont la propriété exclusive du Groupe Thomson-CSF. Elles ne doivent pas être divulguées sans l'accord écrit de Thomson-CSF Optronique.



DT / Génie Optronique

Information included in this document are Thomson-CSF group's own property. These ones shall not be disclosed without the prior written consent of Thomson-CSF Optronique.

REF_T00_EN - Outil PowerPoint

THOMSON-CSF OPTRONIQUE



Scope

- New missions increase demands on system adaptability to environment constraints leading
 - ◆ to support complex system-level functions such as multi-sensors data acquisitions, multi-bands data fusion.
- Digital processing and opto-mechanical sub-systems/components support more and more functions leading
 - ◆ to an increase complexity to predict the global behavior and performances of the system before any development or integration.



DT / Génie Optronique

Information included in this document is Thomson-CSF group's own property. These ones shall not be disclosed without the prior written consent of Thomson-CSF Optronique.

REF_T00_EN - Outil PowerPoint



Goals

- Use « synthetic environment » simulations
 - ◆ to validate system missions with the customer,
 - ◆ to avoid « gap » with the customer and help him to describe the operational requirements.
- Use « executable formalisms » simulations
 - ◆ to verify soundness of system control logic,
 - ◆ to explicit concurrent properties between system functions.
- Connect both types of simulations
 - ◆ to co-validate missions & high-level behavior.



DT / Génie Optronique

Information included in this document is Thomson-CSF group's own property. These ones shall not be disclosed without the prior written consent of Thomson-CSF Optronique.

REF_T00_EN - Outil PowerPoint

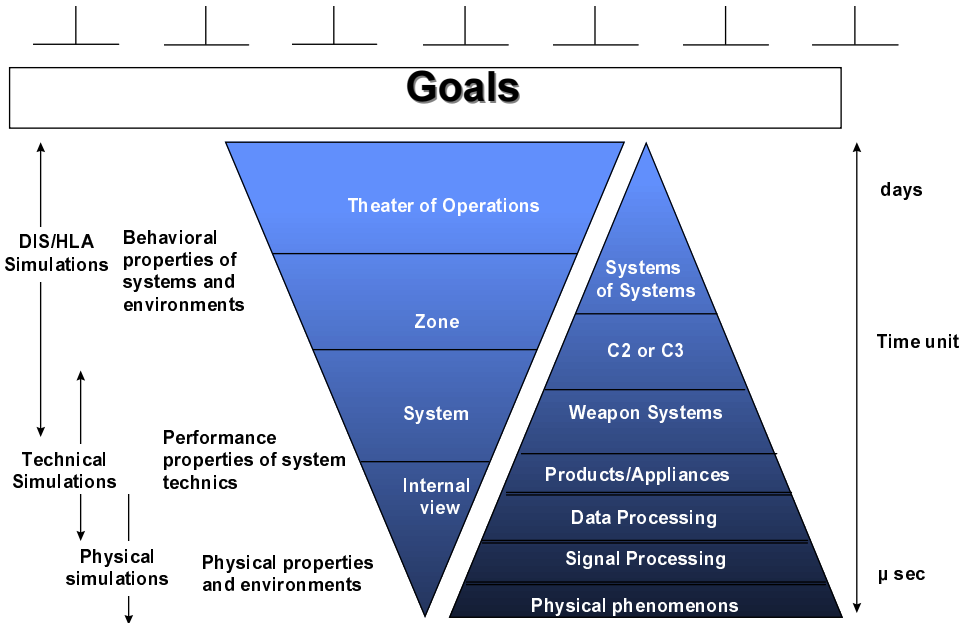

Optronics Systems and Simulations Architecture

Information included in this document is Thomson-CSF group's own property. These ones shall not be disclosed without the prior written consent of Thomson-CSF Optronique.

Les informations contenues dans ce document sont la propriété exclusive du Groupe Thomson-CSF. Elles ne doivent pas être divulguées sans l'accord écrit de Thomson-CSF Optronique.

THOMSON-CSF OPTRONIQUE



Generic IRST Optronic System

- Class of passive military infrared sensor systems.
- Reliably detect and track targets.
- Components :
 - ◆ Infrared sensor, IRST computer, track files database, display hardware.
- Inputs :
 - ◆ A continuous sequence of infrared image frames of background clutter with or without target.



DT / Génie Optronique

Information included in this document is Thomson-CSF group's own property. These ones shall not be disclosed without the prior written consent of Thomson-CSF Optronique.

REF. TOC_EN - Outil/PowerPoint

Information included in this document are Thomson-CSF group's own property. These ones shall not be disclosed without the prior written consent of Thomson-CSF Optronique.



IRST Simulation Architecture

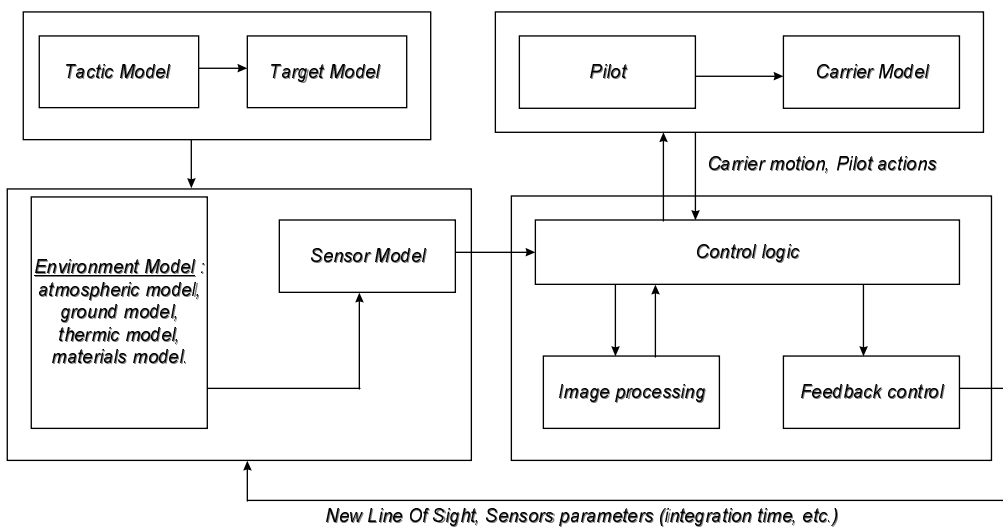

DT / Génie Optronique

Information included in this document is Thomson-CSF group's own property. These ones shall not be disclosed without the prior written consent of Thomson-CSF Optronique.

REF. TOC_EN - Outil/PowerPoint

Les informations contenues dans ce document sont la propriété exclusive du Groupe Thomson-CSF. Elles ne doivent pas être divulguées sans l'accord écrit de Thomson-CSF Optronique.



Current practice in system analysis and design

Information included in this document are Thomson-CSF group's own property. These ones shall not be disclosed without the prior written consent of Thomson-CSF Optronique.



DT / Génie Optronique

Information included in this document are Thomson-CSF group's own property. These ones shall not be disclosed without the prior written consent of Thomson-CSF Optronique.

REF. TOC_EN - Outil/PowerPoint



Current practice

- External functional analysis
 - ◆ Operational scenarios definition
 - ◆ Functional decomposition by mode (SA/RT)
 - ◆ Performance allocation
- Internal functional analysis
 - ◆ Functional decomposition using technical solutions
 - ◆ Input / Output definition
 - ◆ Performance induction
- System Architecture definition
 - ◆ Components definition
 - ◆ Functions allocated to components

Les informations contenues dans ce document sont la propriété exclusive du Groupe Thomson-CSF. Elles ne doivent pas être divulguées sans l'accord écrit de Thomson-CSF Optronique.



DT / Génie Optronique

Information included in this document are Thomson-CSF group's own property. These ones shall not be disclosed without the prior written consent of Thomson-CSF Optronique.

REF. TOC_EN - Outil/PowerPoint

THOMSON-CSF OPTRONIQUE

Information included in this document are Thomson-CSF group's own property. These ones shall not be disclosed without the prior written consent of Thomson-CSF Optronique.

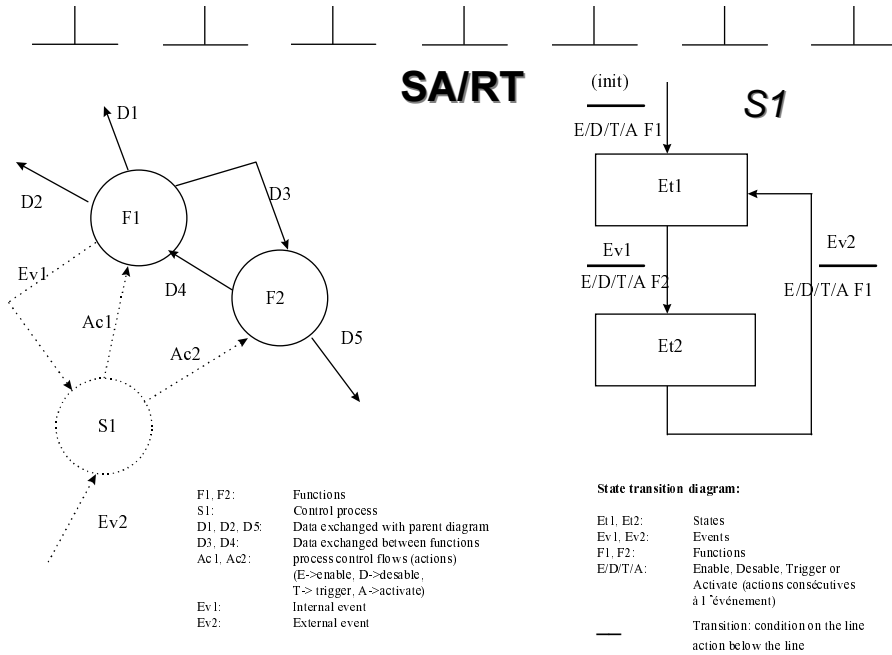

THOMSON-CSF
OPTRONIQUE

DT / Génie Optronique

Information included in this document are Thomson-CSF group's own property. These ones shall not be disclosed without the prior written consent of Thomson-CSF Optronique.

REF_TCO_LEN - Outil PowerPoint

Les informations contenues dans ce document sont la propriété exclusive du Groupe Thomson-CSF. Elles ne doivent pas être divulguées sans l'accord écrit de Thomson-CSF Optronique.

SA/RT Exemple 1/2

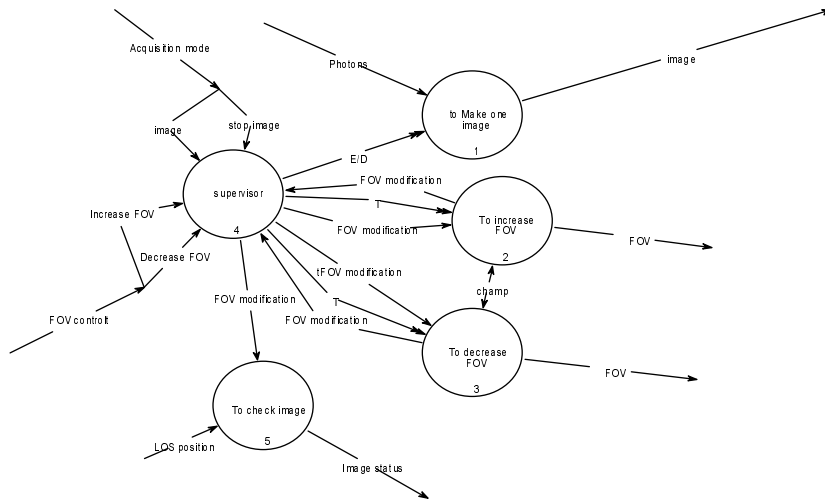

THOMSON-CSF
OPTRONIQUE

DT / Génie Optronique

Information included in this document are Thomson-CSF group's own property. These ones shall not be disclosed without the prior written consent of Thomson-CSF Optronique.

REF_TCO_LEN - Outil PowerPoint

SA/RT Exemple 2/2 (supervisor)

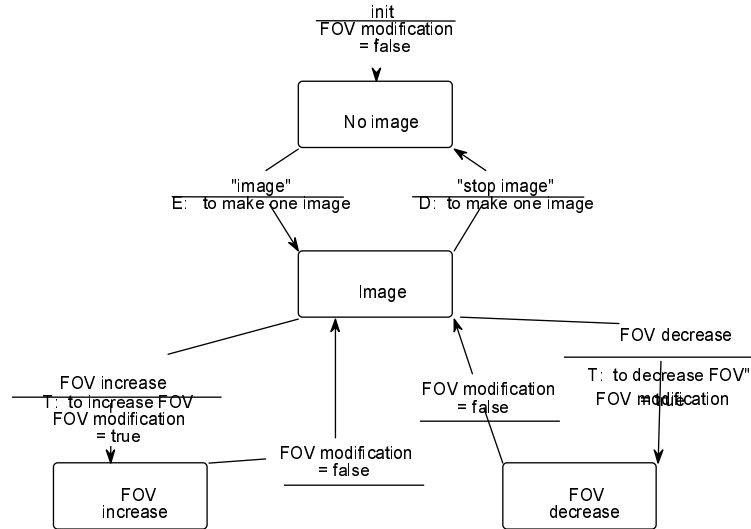

Raised problems

- No validation
 - ◆ No check of the consistency of the system behavior
 - ◆ Partial use of operational scenarios (no check of the completeness of the system behavior)
- No continuity between functional analysis and system architecture definition
 - ◆ New diagrams (consistency?)
- Several models, simulation tools, configuration management.



Current practice in «Distributed Modeling & Simulation»

Information included in this document are Thomson-CSF group's own property. These ones shall not be disclosed without the prior written consent of Thomson-CSF Optronique.

REF. TOCLEN - Outil PowerPoint



DT / Génie Optronique

Information included in this document are Thomson-CSF group's own property. These ones shall not be disclosed without the prior written consent of Thomson-CSF Optronique.



DoD/DMSO

- Additional M&S Dimensions**
- Level of Resolution
 - Degree of Human Participation
 - Degree of Physical Realism
 - Time Management Method
 - Time Step Resolution
 - Degree of Distribution
 - Computational Complexity



Two recent Defense Science Board (DSB) Task Forces (Reports on Advanced Distributed Simulation and Readiness, references (1) and (2)) have recommended that architectural efforts to combine live, virtual, and constructive simulation be broadened.

In addition, recent special studies have noted the need for architectural activities to promote the interoperability and reuse of models and simulations to support other functional areas such as acquisition (Report on M&S, reference (e)). Interoperability and reuse are limited because the Department of Defense lacks a common technical framework for simulation architecture.

There is now a consensus that DoD must establish such a framework to facilitate the interoperability of all types of models and simulations among themselves and with C4I Systems, as well as to facilitate the reuse of M&S components.

(1) Defense Science Board, Office of the Under Secretary of Defense for Acquisition, "Report of the Defense Science Board Task Force on Advanced Distributed Simulation," August 1994

(d) Defense Science Board, Office of the Under Secretary of Defense for Acquisition and Technology, "Report of the Defense Science Board Task Force on Readiness," June 1994

From the Simulation Based Design (SBD) project

Les informations contenues dans ce document sont la propriété exclusive du Groupe Thomson-CSF. Elles ne doivent pas être divulguées sans l'accord écrit de Thomson-CSF Optronique.

REF. TOCLEN - Outil PowerPoint



DT / Génie Optronique

Information included in this document are Thomson-CSF group's own property. These ones shall not be disclosed without the prior written consent of Thomson-CSF Optronique.

THOMSON-CSF OPTRONIQUE



The proposed Methodology

The co-validation approach

Information included in this document are Thomson-CSF group's own property. These ones shall not be disclosed without the prior written consent of Thomson-CSF Optronique.

REF_T00_EN - Outil/PowerPoint



DT / Génie Optronique

Information included in this document are Thomson-CSF group's own property. These ones shall not be disclosed without the prior written consent of Thomson-CSF Optronique.



One model, three Views

- Provide one model, with several views adapted to each development stages:
 - ◆ A behavioral view
 - to check consistency of the system behavior,
 - ◆ An operational view
 - to check completeness of the system behavior,
 - ◆ An architectural view
 - to refine the system behavior in terms of components and a reference architecture.

Les informations contenues dans ce document sont la propriété exclusive du Groupe Thomson-CSF. Elles ne doivent pas être divulguées sans l'accord écrit de Thomson-CSF Optronique.

REF_T00_EN - Outil/PowerPoint



DT / Génie Optronique

Information included in this document are Thomson-CSF group's own property. These ones shall not be disclosed without the prior written consent of Thomson-CSF Optronique.

THOMSON-CSF OPTRONIQUE



The Behavioral View

- Complex systems such as multi-sensors Optronics systems have to be reactive to events coming from their environment :
 - ◆ For instance, sensors Line Of Sight may have to change according to scene updates, pilot commands, data fusion results, target recognition, etc.
 - ◆ How these events must be handled ? Which priorities must be followed ?
 - ◆ How to ensure the specifications don't forget a particular combinaison of happening events?
- Since [Harel 1986], the statechart approach has shown to be useful to model reactive systems.
 - ◆ Relatives researches : Gajski/SpecCharts (University of Stanford), Esterel/SyncCharts (INRIA/CMA), Ptolemy/*Charts (UC Berkeley).
 - ◆ Hierarchical Finite State Machines (FSMs) to process events,
 - ◆ concurrent models between FSMs to model collaboration between system functions.



The Behavioral View

- to validate the consistency of the system behavior :
 - ◆ checking of the system modes specification with the Hierarchical Finite States Machine formalism,
 - ◆ checking of the delays across the system with the Discrete events formalism.
- The specifier uses these formalisms to figure out how the system must behave and react to external and internal events according to the requirements.
- Other formalisms may be selected to meet, for instance, fault-tolerant constraints.

THOMSON-CSF OPTRONIQUE



The Operational View

- To validate the completeness of the system behavior
 - ◆ the missions of the system through scenarios :
 - tactical environment definition,
 - ◆ the Human/System Interface :
 - symbology,
 - controls (joystick, etc.),
 - visual definitions.
- The customer and the specifier agree on what must be the system behavior, and missions.



DT / Génie Optronique

Information included in this document is Thomson-CSF group's own property. These ones shall not be disclosed without the prior written consent of Thomson-CSF Optronique.

REF_T00_EN - Outil PowerPoint



The Architectural View

- Refinement of the model in terms of components and an architecture :
 - ◆ components capture technical functions :
 - processing components,
 - control components,
 - sensors and actuators components,
 - etc.
 - ◆ architecture captures interactions between components :
 - models of concurrency, communication and control.
 - ◆ definition of component interface with the architecture and avoid direct dependancy between components.
- Last stage before technology choices !



DT / Génie Optronique

Information included in this document is Thomson-CSF group's own property. These ones shall not be disclosed without the prior written consent of Thomson-CSF Optronique.

REF_T00_EN - Outil PowerPoint

Information included in this document are Thomson-CSF group's own property. These ones shall not be disclosed without the prior written consent of Thomson-CSF Optronique.

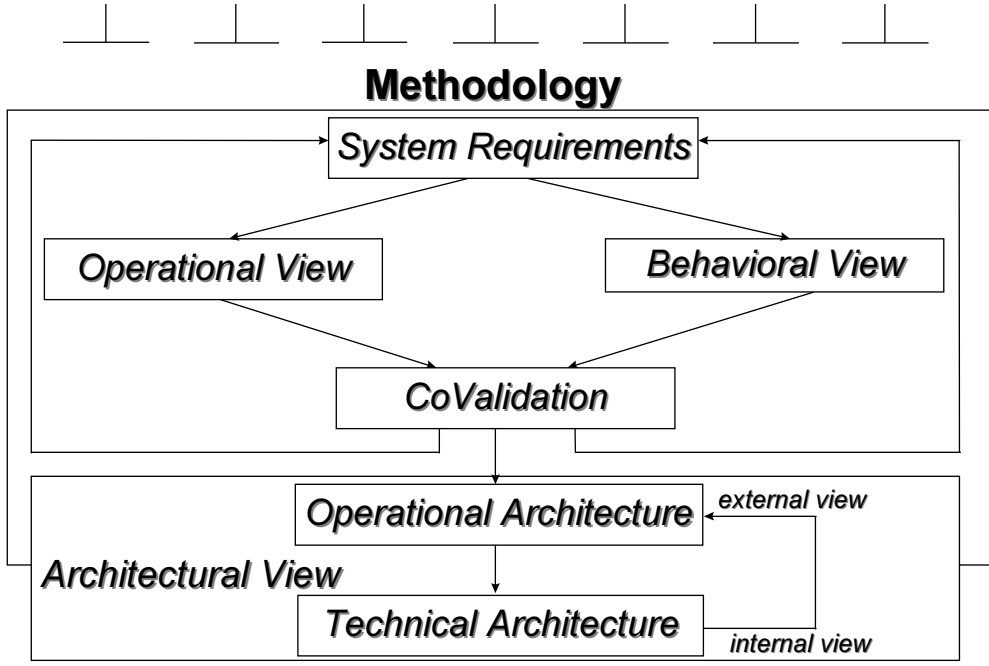

Les informations contenues dans ce document sont la propriété exclusive du Groupe Thomson-CSF. Elles ne doivent pas être divulguées sans l'accord écrit de Thomson-CSF Optronique.

The proposed Infrastructure



Why Ptolemy ?

- Formalisms composition :
 - ◆ formalisms may be composed to model the whole system.
- Several formalisms :
 - ◆ DataFlow for processing components,
 - ◆ Finite State Machines for control components,
 - ◆ Discrete Events for performance evaluation.
- An infrastructure with general purpose services :
 - ◆ libraries of reusable components,
 - ◆ graphers,
 - ◆ interfaces with external tools such as Matlab, Mathematica, etc.
 - ◆ openness : source codes available,
 - ◆ extendability : object-oriented framework.



Formalisms composition

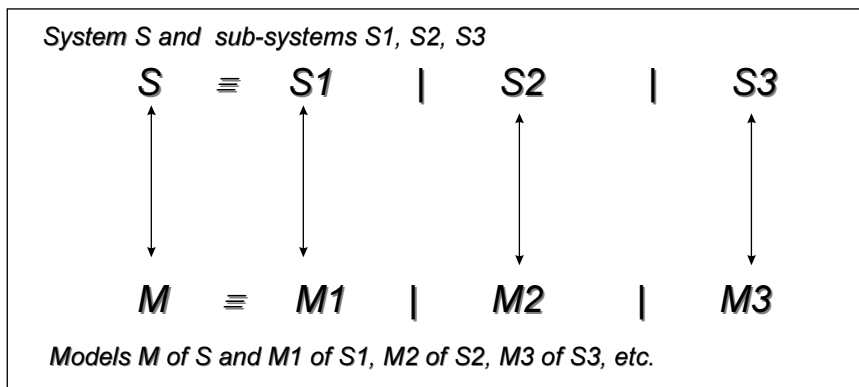

*If M is composed with $M1$, $M2$ and $M3$,
then M is a model of S .*

Information included in this document are Thomson-CSF group's own property. These ones shall not be disclosed without the prior written consent of Thomson-CSF Optronique.



The Ptolemy DIS domain

- Ptolemy is well-suited to support
 - ◆ the Behavioral View of the system model,
 - ◆ and the Architectural View.
- We extended Ptolemy to support
 - ◆ the Operational View through interfaces with the DIS (Distributed Interactive Simulation) standard protocol from DoD DM&S Office.
- The DIS domain is derived from the DE domain
 - ◆ events are dispatched to the inputs of the behavioral model,
 - ◆ outputs of the behavioral model emit events to the operation model.

Les informations contenues dans ce document sont la propriété exclusive du Groupe Thomson-CSF. Elles ne doivent pas être divulguées sans l'accord écrit de Thomson-CSF Optronique.

Time Management Interoperability

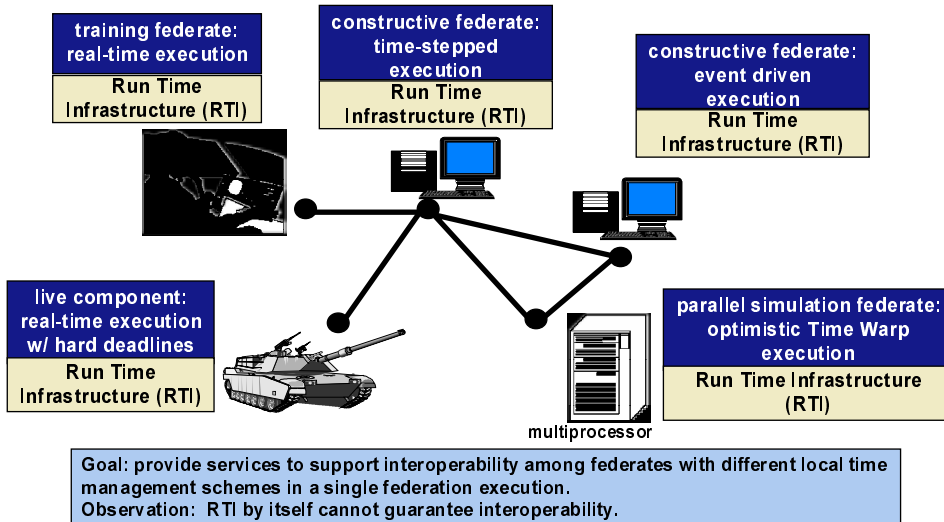

Information included in this document are Thomson-CSF group's own property. These ones shall not be disclosed without the prior written consent of Thomson-CSF Optronique.

Event Driven Federate

Goal: merge TSO messages (events from other federates) with local events so all events are processed in time stamp order

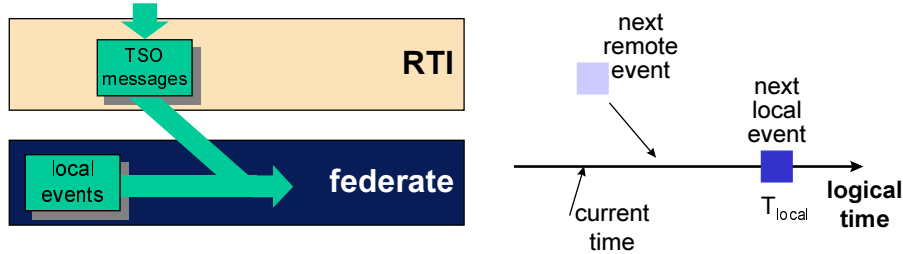

```

while (simulation still in progress)
    invoke Next Event Request ( $T_{local}$  = time stamp of next local event)
    RTI delivers next TSO event w/ time stamp  $\leq T_{local}$  if any exist (+ others w/ same time stamp)
    RTI advances federate's logical time, invokes Time Advance Grant
    if (TSO message(s) delivered in above Next Event Request service call)
        process the remote event(s) delivered to the federate
    else
        process next local event
    
```

Les informations contenues dans ce document sont la propriété exclusive du Groupe Thomson-CSF. Elles ne doivent pas être divulguées sans l'accord écrit de Thomson-CSF Optronique.

Software Architecture

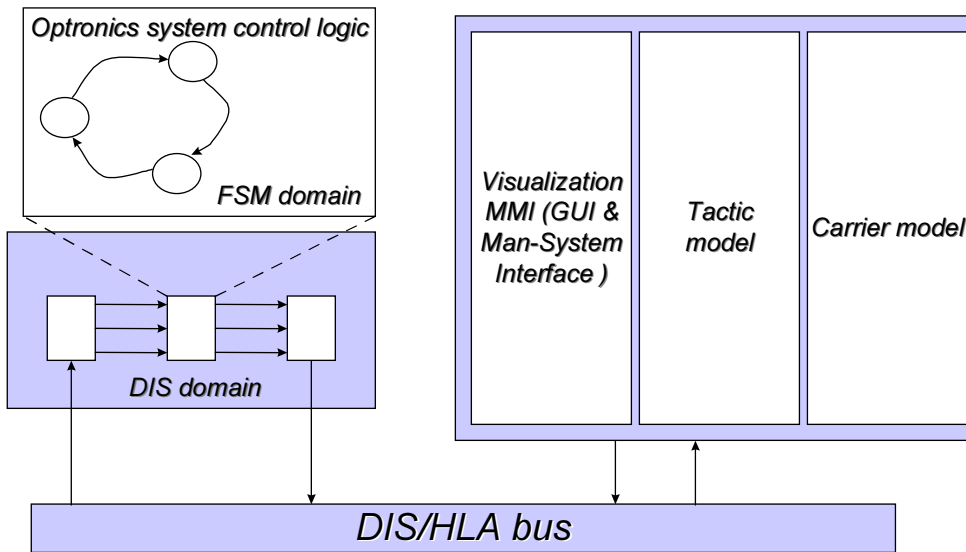



Conclusion and Future Work

Information included in this document are Thomson-CSF group's own property. These ones shall not be disclosed without the prior written consent of Thomson-CSF Optronique.

REF: TOO_EN - Outil PowerPoint



DT / Génie Optronique

Information included in this document are Thomson-CSF group's own property. These ones shall not be disclosed without the prior written consent of Thomson-CSF Optronique.



Conclusion

- Systems definition method improved :
 - ◆ DIS simulations to define systems missions,
 - ◆ Ptolemy simulations to specify systems supervision,
 - ◆ Co-simulations to fill the « gap » between operational and industrial.
- Simulation infrastructure enhanced :
 - ◆ Ptolemy DIS domain prototype.
- Maintainability : better changes management
 - ◆ help to check introduction of new functions in system definition.

Les informations contenues dans ce document sont la propriété exclusive du Groupe Thomson-CSF. Elles ne doivent pas être divulguées sans l'accord écrit de Thomson-CSF Optronique.

REF: TOO_EN - Outil PowerPoint



DT / Génie Optronique

Information included in this document are Thomson-CSF group's own property. These ones shall not be disclosed without the prior written consent of Thomson-CSF Optronique.

THOMSON-CSF OPTRONIQUE



Future Work

- Refinement of behavioral models with :
 - ◆ timing properties, and parametric physical relations or differential equations (CT domain ?)
- Add dead-Reckoning to the Ptolemy DIS domain.

Information included in this document are Thomson-CSF group's own property. These ones shall not be disclosed without the prior written consent of Thomson-CSF Optronique.

REF_T00_EN - Outil PowerPoint



DT / Génie Optronique

Information included in this document are Thomson-CSF group's own property. These ones shall not be disclosed without the prior written consent of Thomson-CSF Optronique.



Demonstration

Les informations contenues dans ce document sont la propriété exclusive du Groupe Thomson-CSF. Elles ne doivent pas être divulguées sans l'accord écrit de Thomson-CSF Optronique.

REF_T00_EN - Outil PowerPoint



DT / Génie Optronique

Information included in this document are Thomson-CSF group's own property. These ones shall not be disclosed without the prior written consent of Thomson-CSF Optronique.

THOMSON-CSF OPTRONIQUE

Information included in this document are Thomson-CSF group's own property. These ones shall not be disclosed without the prior written consent of Thomson-CSF Optronique.

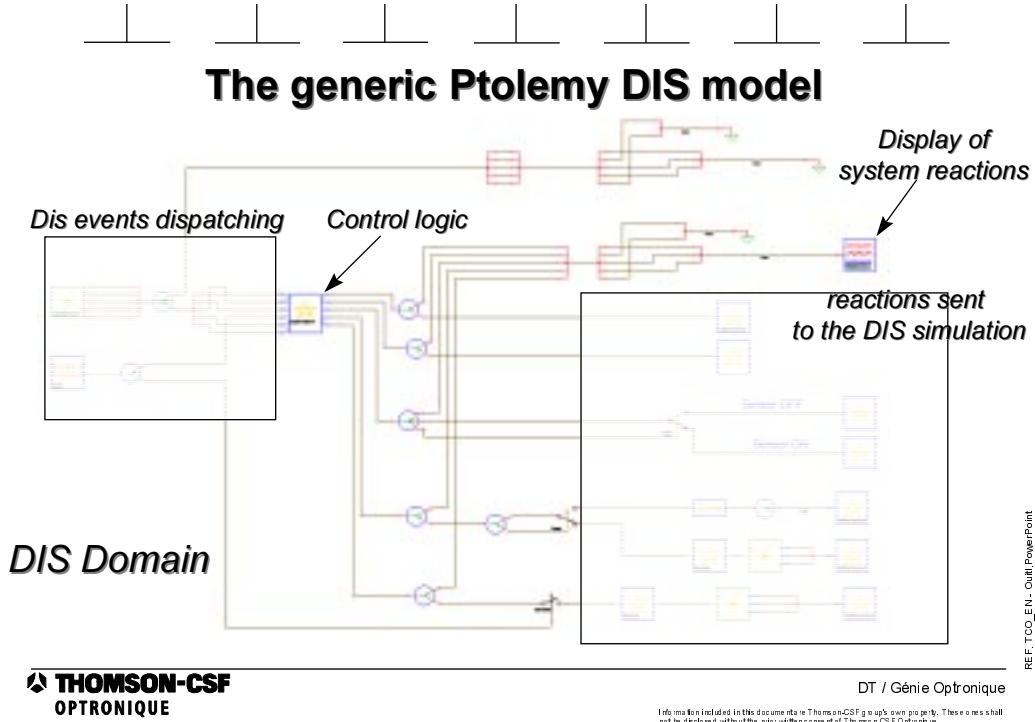

Les informations contenues dans ce document sont la propriété exclusive du Groupe Thomson-CSF. Elles ne doivent pas être divulguées sans l'accord écrit de Thomson-CSF Optronique.

The DIS Target parameters

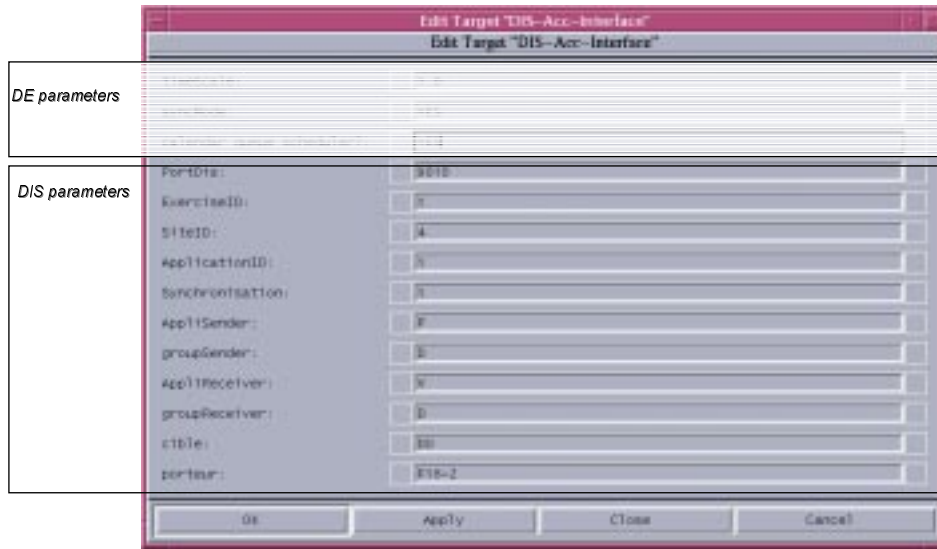

Information included in this document are Thomson-CSF group's own property. These ones shall not be disclosed without the prior written consent of Thomson-CSF Optronique.

DIS events dispatching

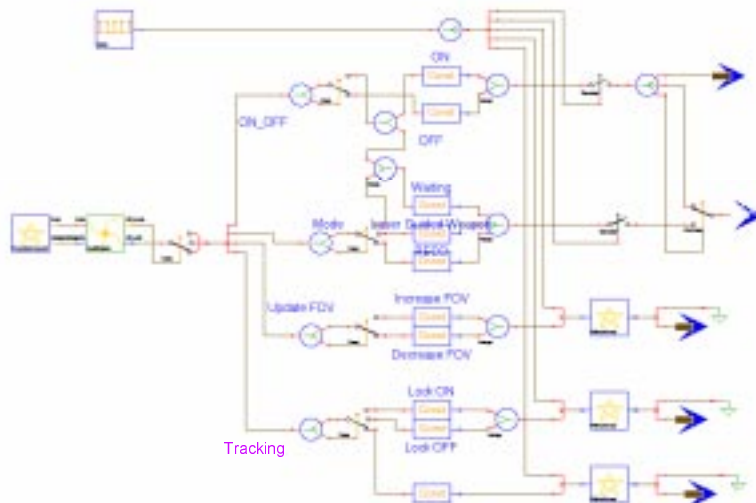

DT / Génie Optronique

Information included in this document are Thomson-CSF group's own property. These ones shall not be disclosed without the prior written consent of Thomson-CSF Optronique.

REF. TOC_EN - OutilPowerPoint

Les informations contenues dans ce document sont la propriété exclusive du Groupe Thomson-CSF. Elles ne doivent pas être divulguées sans l'accord écrit de Thomson-CSF Optronique.

Control Logic



DT / Génie Optronique

Information included in this document are Thomson-CSF group's own property. These ones shall not be disclosed without the prior written consent of Thomson-CSF Optronique.

REF. TOC_EN - OutilPowerPoint

THOMSON-CSF OPTRONIQUE



Lase Guided Weapon Mode

DE domain

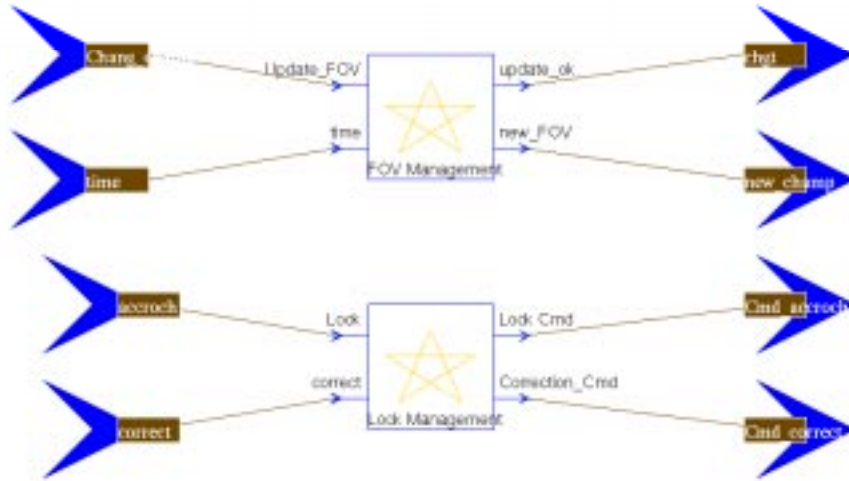

DT / Génie Optronique

Information included in this document is Thomson-CSF group's own property. These ones shall not be disclosed without the prior written consent of Thomson-CSF Optronique.

REF_TCO_EN - Outil PowerPoint

Information included in this document is Thomson-CSF group's own property. These ones shall not be disclosed without the prior written consent of Thomson-CSF Optronique.



Field of View Management

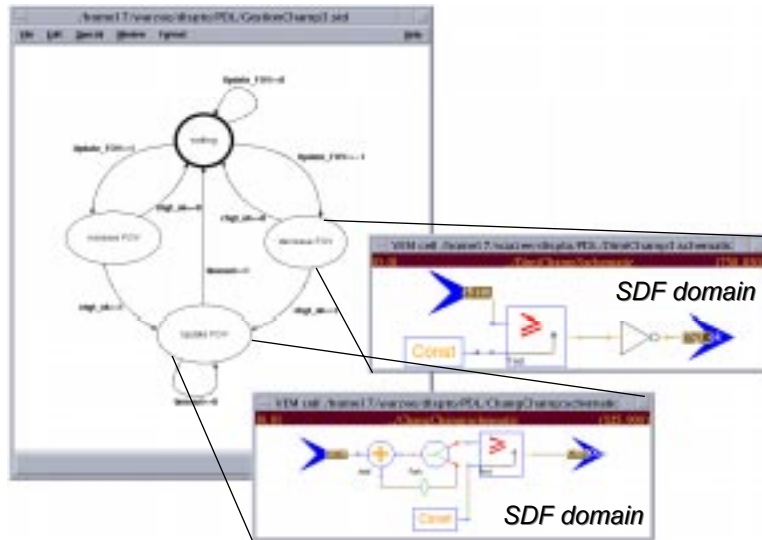

DT / Génie Optronique

Information included in this document is Thomson-CSF group's own property. These ones shall not be disclosed without the prior written consent of Thomson-CSF Optronique.

REF_TCO_EN - Outil PowerPoint

Les informations contenues dans ce document sont la propriété exclusive du Groupe Thomson-CSF. Elles ne doivent pas être divulguées sans l'accord écrit de Thomson-CSF Optronique.

Information included in this document are Thomson-CSF group's own property. These ones shall not be disclosed without the prior written consent of Thomson-CSF Optronique.



Synthetic Environment : Approach & Firing



REF_T00_EN - Outil PowerPoint



DT / Génie Optronique

Information included in this document are Thomson-CSF group's own property. These ones shall not be disclosed without the prior written consent of Thomson-CSF Optronique.

Les informations contenues dans ce document sont la propriété exclusive du Groupe Thomson-CSF. Elles ne doivent pas être divulguées sans l'accord écrit de Thomson-CSF Optronique.



Synthetic Environment : Hit and break

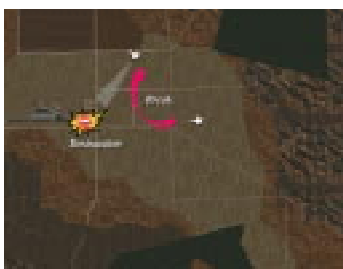

REF_T00_EN - Outil PowerPoint



DT / Génie Optronique

Information included in this document are Thomson-CSF group's own property. These ones shall not be disclosed without the prior written consent of Thomson-CSF Optronique.

THOMSON-CSF OPTRONIQUE



References

- DMSO (Distributed Modeling & Simulation Office) :
 - ◆ <http://www.dmsomil>
- DIS/HLA (Distributed Interactive Simulation/High Level Architecture) :
 - ◆ <http://hla.dmsomil>
- Simulation Based Design Project :
 - ◆ <http://sbdhost.parl.com>
- David Harel :
 - ◆ <http://www.wisdom.weizmann.ac.il/~harel>
- Thomson-CSF Optronique :
 - ◆ <http://ptolemy.thomson-csf.fr/~warzee>



DT / Génie Optronique

Information included in this document is Thomson-CSF group's own property. These ones shall not be disclosed without the prior written consent of Thomson-CSF Optronique.

REF_T00_LN...QuillPowerPoint

Information included in this document is Thomson-CSF group's own property. These ones shall not be disclosed without the prior written consent of Thomson-CSF Optronique.

Les informations contenues dans ce document sont la propriété exclusive du Groupe Thomson-CSF. Elles ne doivent pas être divulguées sans l'accord écrit de Thomson-CSF Optronique.